



brennenstuhl®



SICHERHEITSINFORMATIONEN

SAFETY INFORMATION

DE Sicherheitsinformationen

EN Safety information

FR Informations sur la sécurité

NL Veiligheidsinformatie

IT Informazioni sulla sicurezza

SE Säkerhetsinformation

ES Información de seguridad

PL Informacje dotyczące
bezpieczeństwa

CZ Bezpečnostní informace

HU Biztonsági információk

RU Информация о безопасности

TR Güvenlik bilgileri

FI Turvallisuustiedot

GR Πληροφορίες για την ασφάλεια

PT Informações de segurança

EE Ohutusalane teave

SK Bezpečnostné informácie

SI Varnostne informacije

LT Saugos informacija

LV Drošības informācija

HR Sigurnosne informacije

RO Informații privind siguranța

BG Информация за безопасност

DK Oplysninger om sikkerhed

NO Sikkerhetsinformasjon

UA Інформація з техніки безпеки

AR معلومات السلامة

WWW.BRENNENSTUHL.COM

04/11/2024

Front silk screen

 PANTONE Cool Gray 10 C

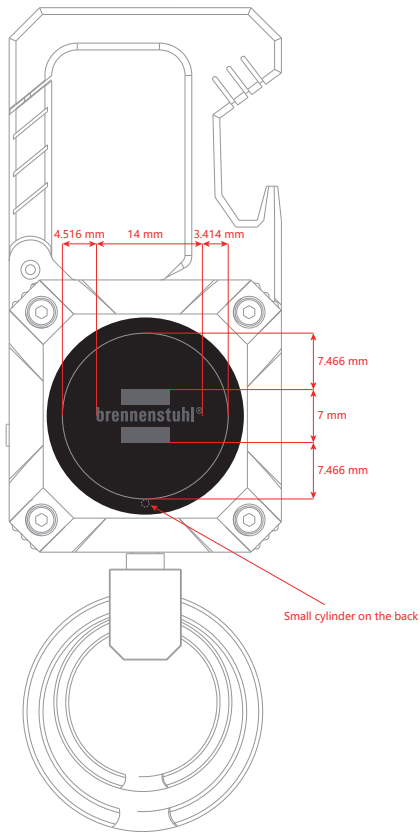

Back

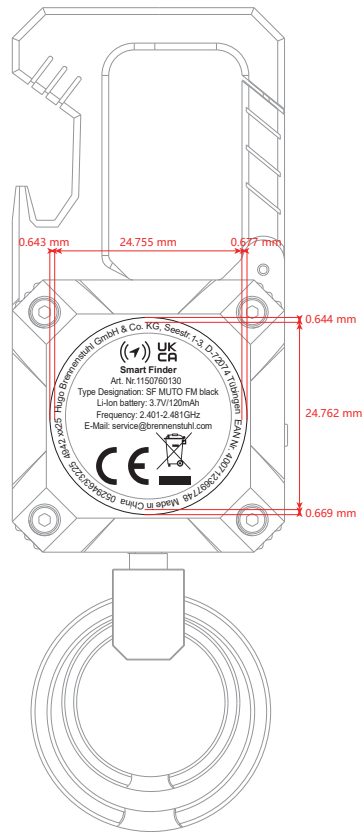

Left side

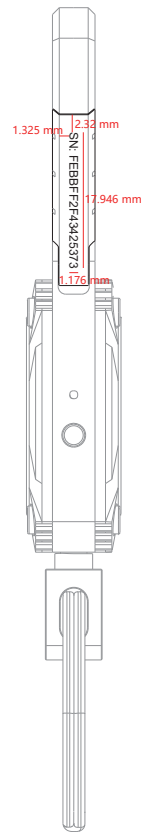

brennenstuhl®

brennenstuhl®

Smart Finder

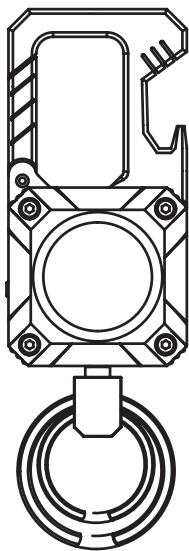

  www.brennenstuhl.com

DE Smart Finder
EN Smart Finder
FR Recherche intelligente
NL Smart Finder
IT Ricerca intelligente
SE Smart sökmotor
ES Buscador inteligente
PL Inteligentna wyszukiwarka
CZ Chytrý vyhledávač
HU Intelligens kereső
RU Умный поисковик
TR Akıllı bulucu
FI Älykäs hakutoiminto
GR Έξυπνος εντοπιστής
PT Localizador inteligente

EE Nutikas otsija
SK Inteligentný vyhľadávač
SI Pametni iskalnik
LT Viedis meklētājs
LV Išmanīsis iekšiklis
HR Intelligens kereső
RO Căutare inteligentă
BG Интелигентен търсач
DK Smart søgemaskine
NO Smart søkemotor
UA Розумний пошуковик
JP スマートファインダー
KR 스마트 파인더
AR الباحث الذكي

The Apple Find My network provides an easy, secure way to locate compatible personal items using the Find My app on your iPhone, iPad, Mac or the Find Items app on Apple Watch. To use the Apple Find My app to locate this item, the latest version of iOS, iPadOS or macOS is recommended. The Find Items app on Apple Watch requires the latest version of watchOS. Use of the Works with Apple badge means that a product has been designed to work specially with the technology identified in the badge and has been certified by the product manufacturer to meet Apple Find My network product specifications and requirements. Apple is not responsible for the operation of this device or use of this product or its compliance with safety and regulatory standards. Apple, Apple Find My, Apple Watch, Find My, iPhone, iPad, iPadOS, Mac, macOS and watchOS are trademarks of Apple Inc. iOS is a trademark or registered trademark of Cisco in the U.S. and other countries and is used under license.

Hugo Brennenstuhl GmbH & Co. KG
Seestr. 1-3 · D-72074 Tübingen

www.brennenstuhl.com
service@brennenstuhl.com
service.brennenstuhl.com



SF MUTO FM black
Art.-Nr.: 1150760130

Li-Ion battery:
3.7V / 120mAh
Frequency:
2.401 - 2.481 GHz

0534927/4925 - Made in China

 **lo Riciclo**
ASTUGGO
RACCOLTA DIFFERENZIATA SECONDO LE REGOLE DEL TUO COMUNE

VALIDO SOLO IN ITALIA
VALID ONLY IN ITALY
Carta → PRP 21



65.5*102.5MM

<p>User Manual Smart Finder SF M1020 FM black</p> <p>Works with Apple Find My</p>	<p>Setting up Your iPhone Compatibility This device is only compatible with iPhone 8 series or later, iPhone running iOS 14.0 or later with Two-Factor Authentication turned on.</p> <p>1. Turn on Two-Factor Authentication for your iPhone Go to Settings > your name > Two-Factor Authentication > Turn On.</p> <p>2. Turn on Two-Factor Authentication for your Apple ID Go to Settings > Apple ID > Account & Security > Turn On Two-Factor Authentication.</p> <p>3. Turn on Find My Go to Settings.</p> <p>4. Turn on Bluetooth</p> <p>5. Connect to a stable Wi-Fi or cellular network</p> <p>6. Turn on Location Services Go to Settings > Privacy & Security > Location Services > System Location Services.</p>	<p>Getting Started Power on Press the key's power button once, and a light will flash to indicate that it is turned on.</p> <p>Power off To turn off the power, press the power button 5 times in a row. After pressing each time, the key will vibrate and the light will flash. The key is turned off. If the key has not been powered within 10 minutes, a beep will be heard and the power will automatically turn off. Turn on the power to continue pairing.</p> <p>Factory reset To reset your key, press the power button 5 times in a row. After pressing each time, the key will vibrate and the light will flash. The key is turned off. If the key has not been powered within 10 minutes, a beep will be heard and the power will automatically turn off. Turn on the power to continue pairing.</p> <p>Pairing Your Key 1. Ensure your iPhone is set up with "Settings" > "Find My" turned on and your key is powered on. 2. Open the Find My app. 3. Tap the Find My app. 4. In the Items tab, tap Add New Item. 5. Tap Other Supported Item. Your iPhone will search for your key. 6. Once your key is detected, tap Connect. 7. Follow the on-screen steps to name it and register it to your Apple ID. 8. Ensure your key appears in Items. If not, forget the device, perform a factory reset on the key (see "Setting Back to Factory reset" above), then reconnect. 9. Do not leave Find My app while pairing key.</p>	<p>Locating Your Key Locate your key in the map 1. Open the Find My app. 2. Tap the Items tab. 3. Select your key in the Items list. 4. Tap Directions to open the location of your key and get directions in the Maps app.</p> <p>Play sound alert 1. Open the Find My app. 2. Tap the Items tab. 3. Select your key in the Items list and tap Play Sound. *The sound alert will only play if your iPhone is connected to a network, and your key is in Bluetooth range of your iPhone (approx. 100ft/30m).</p> <p>Set up Notify When Left Behind If your key is not in Bluetooth range of your iPhone for a period of time, you will receive a notification that your key has been left. If you set up a notification, the items will be deployed.</p> <p>Pairing Your Key 1. Open the Find My app. 2. Tap the Items tab. 3. Select your key in the Items list and scroll down. 4. Tap Notify When Left Behind and turn on. 5. Select your key in the Items list and scroll down. 6. Tap Notify When Left Behind and turn on. 7. Open the Find My app. 8. Tap the Items tab. 9. Select your key in the Items list and scroll down. 10. Ensure Notify When Left Behind is turned on.</p>	<p>5. Under Last Made, tap Enable, then tap Continue.</p> <p>6. Enter your phone number and email address so that the Finder of your key can contact you, then tap Activate.</p> <p>Changing the Name of Your Key 1. Open the Find My app. 2. Tap the Items tab. 3. Select your key in the Items list. 4. Tap Details and tap Rename Item. 5. Select a name from the list or enter a Custom Name. 6. Tap Done.</p> <p>Removing Your Key Removing your key from your Apple ID will allow it to be activated and used by another person. 1. Ensure that your key is connected to your iPhone.* 2. In the Items tab, tap the key. 3. Tap Remove Item. To Remove or confirm to remove. *If you cannot find the remaining power from your Apple ID, it will no longer be removable and you will need to perform a factory reset before creating a new connection (see "Setting Back to Factory reset").</p> <p>Unwanted Tracking Notification If your key is registered from your iPhone and is detected nearby with another person with an Apple device over time, that person will receive a tracking alert message.</p> <p>Safety Warnings 1. Do not expose the device to an temperature below -10°C (14°F) or above 35°C (95°F). 2. Do not expose the device to an open flame, ultraviolet light, water, or vapor. If it rains in this will damage the device. 3. Avoid sharp damage to the device, cables, or other accessories before using the device. If damaged, do not use the device. 4. Do not attempt to disassemble, modify, or use sharp objects to damage the device in any way, as it may cause serious damage and void the warranty.</p>	<p>5. Do not expose the device to corrosion liquids, or high humidity, as they will seriously damage the device and void the warranty.</p> <p>Charging Your Key To use the included cable to charge. Charging the status light will turn orange. When fully charged, the status light will turn green.</p> <p>To be recommended to fully charge your key once every 4 months.</p> <p>The Apple Find My network provides an easy, secure way to locate compatible personal items using the Find My app on your iPhone, iPad, Mac, or the Find My app on your Apple Watch.</p> <p>To use the Apple Find My app, you need to have the latest version of iOS, iPadOS, or macOS. It is recommended that you have the latest version of the Find My app on your Apple Watch.</p> <p>Use of the Works with Apple badge means that a product has been designed to work specifically with the technology (open/closed) in the badge and has been certified by the product manufacturer to meet Apple Find My network product specifications and requirements. Apple is not responsible for the operation of this device or use of this product as its compliance with the Declaration of Conformity is available at the following internet address: Apple, Apple Find My, Apple Watch, Find My, iPhone, iPad, macOS, Mac, macOS and watchOS are trademarks of Apple Inc. iOS is a trademark or registered trademark of Apple Inc. in the U.S. and other countries and is used under license.</p> <p>More Specific Info 1. How do I know the status light when fully charged? After activating the device, the status light will turn orange. When fully charged, the status light will turn green. 2. How do I know the remaining power? iPhone 8 Series: Later will display the remaining battery level of the device. 3. How long does it take to fully charge the battery? 10-15hrs. 4. Charging indicator light - Full Charging: Green light - Half Charging: Green light</p> <p>Disposal Do not throw electrical appliances in the household waste Electrical and electronic equipment should be disposed of separately and recycled in an environmentally sound manner. You can find out how to dispose of your used appliance from your local or municipal authority.</p>	<p>watchOS are trademarks of Apple Inc. iOS is a trademark or registered trademark of Apple Inc. in the U.S. and other countries and is used under license.</p> <p>More Specific Info 1. How do I know the status light when fully charged? After activating the device, the status light will turn orange. When fully charged, the status light will turn green. 2. How do I know the remaining power? iPhone 8 Series: Later will display the remaining battery level of the device. 3. How long does it take to fully charge the battery? 10-15hrs. 4. Charging indicator light - Full Charging: Green light - Half Charging: Green light</p> <p>Disposal Do not throw electrical appliances in the household waste Electrical and electronic equipment should be disposed of separately and recycled in an environmentally sound manner. You can find out how to dispose of your used appliance from your local or municipal authority.</p>	<p>UK Simplified UK declaration of conformity The company Hugs Brennstuhl GmbH & Co. KG, Hannover, declares that the radio equipment type SF M1020 FM black complies with the Directive 2011/65/EU, 2012/19/EU and 2014/53/EU. The full text of the UK Declaration of Conformity is available at the following internet address: www.brennstuhl.com/declarationofconformityuk_1107202102.pdf</p> <p>This device complies with the legal, national and European requirements. All company names and product designations contained are trademarks of their respective owners.</p> <p>Hugs Brennstuhl GmbH & Co. KG Scheidt 3, D-37274 Volkmershausen Hannover, Germany E-Mail: info@brennstuhl.com Phone: +49 (0)5103 400-0 www.brennstuhl.com</p>
---	--	---	--	---	---	--	---

000002/2022

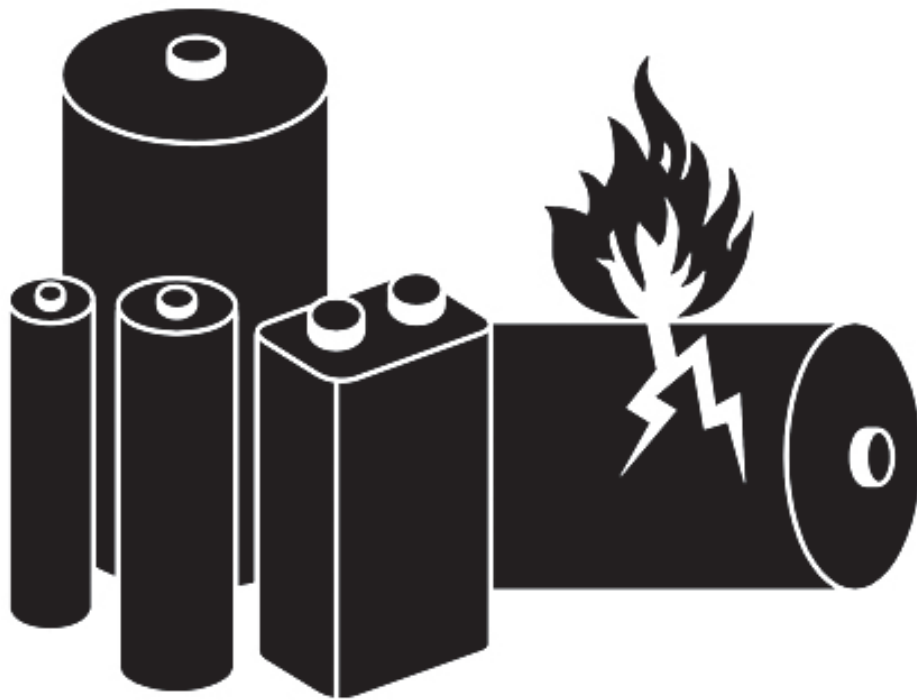

UN 3481

